

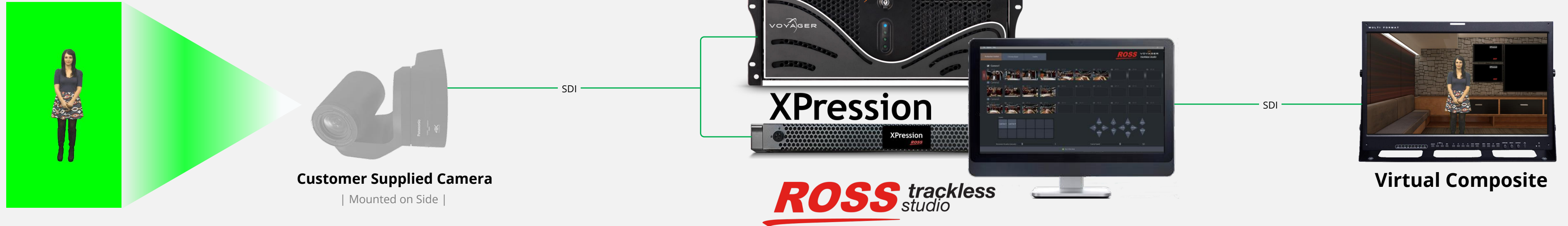

## Trackless Virtual solutions

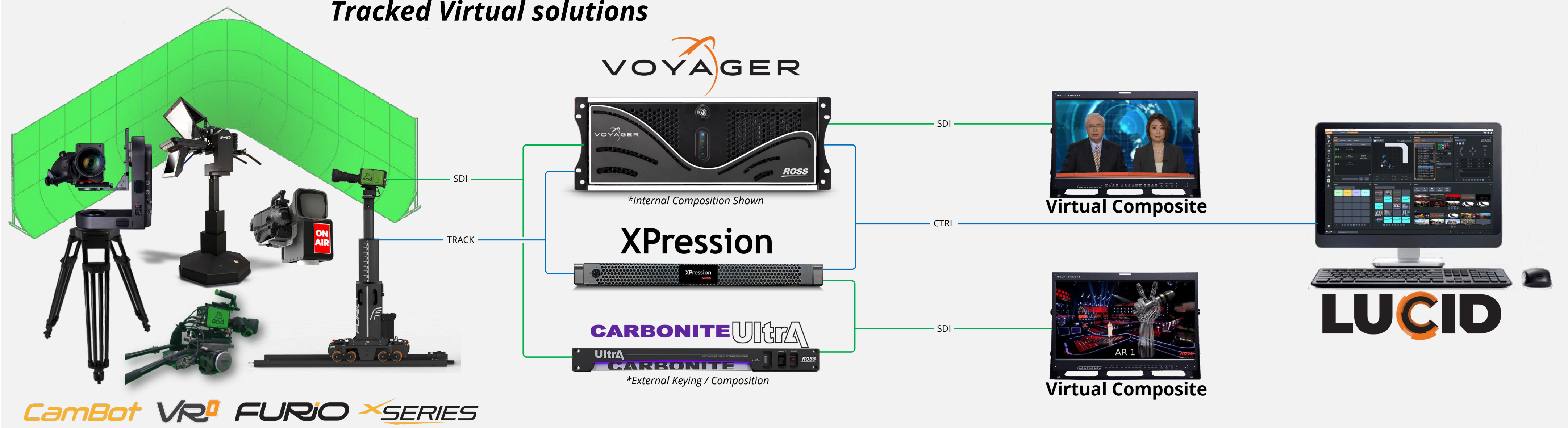

## Tracked Virtual solutions



### LUCID

- Control all Camera chains from one interface
- Quickly build and Save Tracking Calibrations
- Trigger assets, Camera moves and more with Rosstalk triggers
- Newsroom and Data integration

### VOYAGER

- Built on the Unreal Engine
- Hyper realistic rendering
- Realtime reflections and shadows
- Support for both External and Internal compositing
- Internal or External Chroma keying
- Tracked & Trackless Solutions

### XPRESSION

- User friendly Design and playout system
- MOS capable Virtual Engine
- Built for Dynamic Data driven Graphics
- Single platform for insert Graphics, Augmented reality, Virtual sets, and monitor walls
- External Composition & Chroma keying only
- Tracked & Trackless Solutions

### Furio | CamBot | VR0

- Furio**
  - Tracking PT Heads, Lifts and Dolly systems
- CamBot**
  - Heavy Duty Robust XY Pedestals with Tracking data
- VR0**
  - Tracking Data Module for Encoded Tripods and Lenses

### CARBONITE ULTRA

- SD / HD / 3G / UHD
- Input Video Delay
- Up to 4x Chroma Keyers
- Composite on SW or Feed External Fill / Key
- Control Via Panel or Dashboard

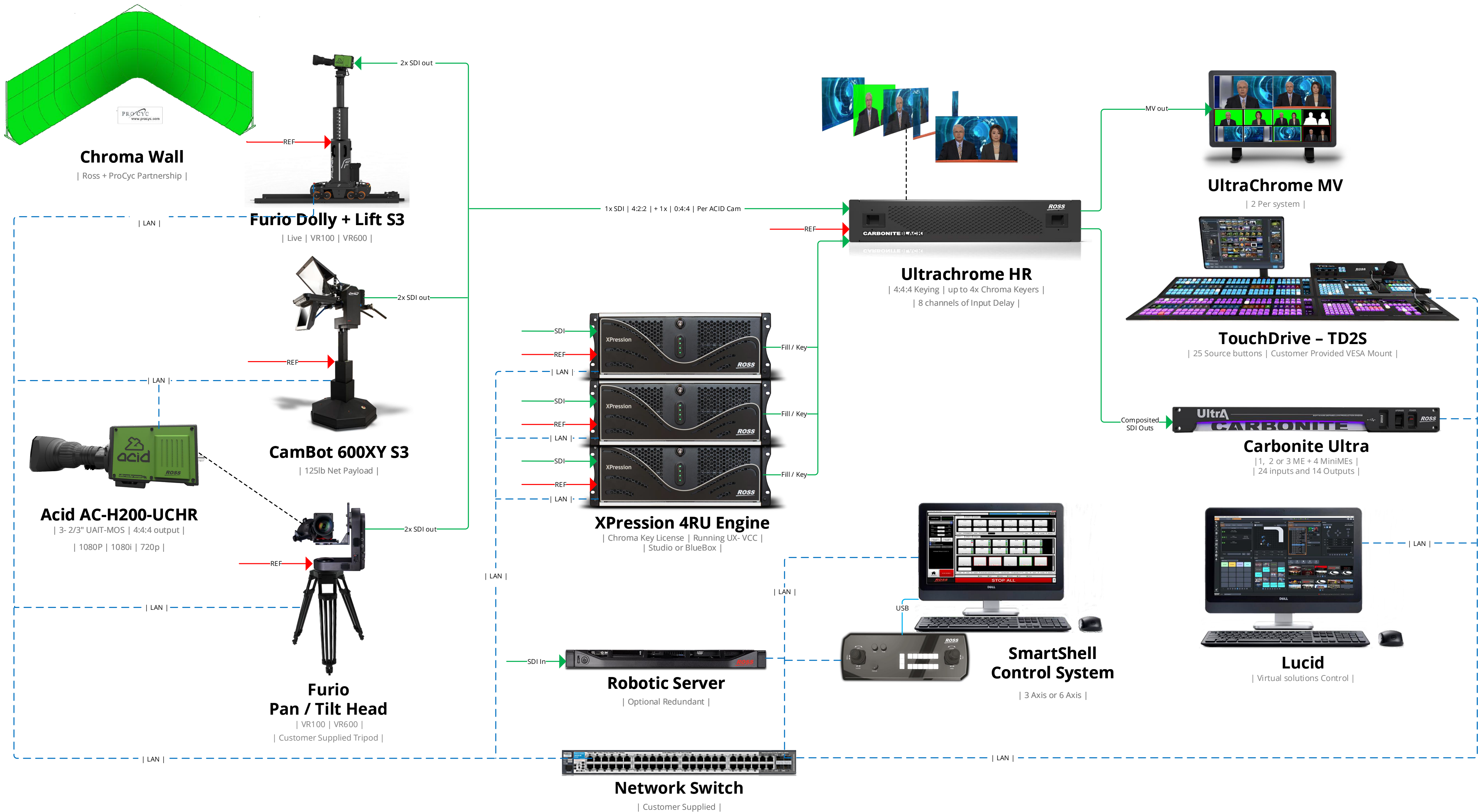

# Ross ARVS External Composition

Furio | CamBot | XPression | Lucid | UltrachromeHR | Carbonite Ultra |



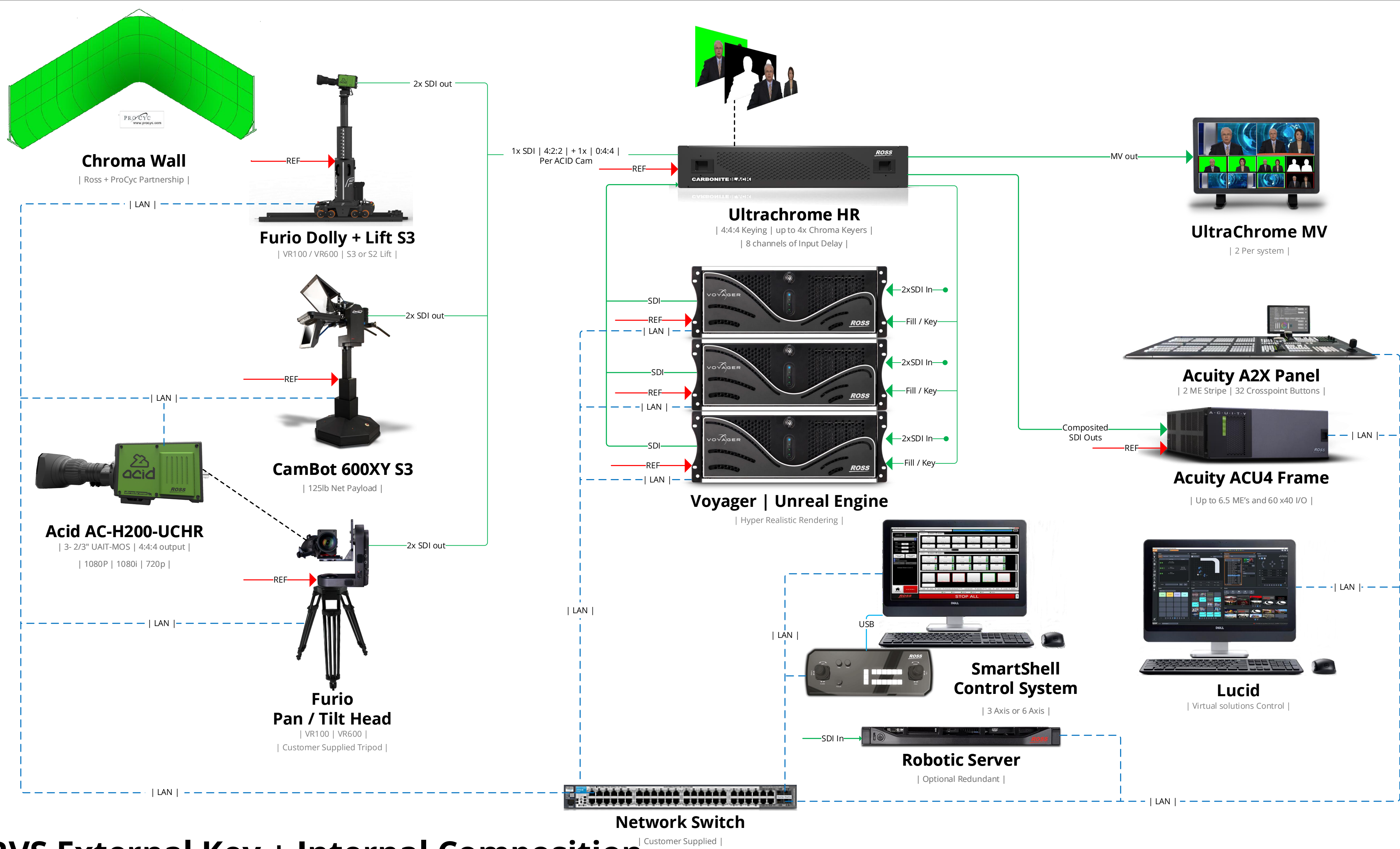
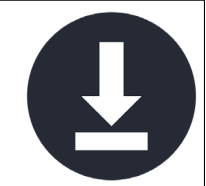

# Ross ARVS External Key + Internal Composition

Furio | CamBot | Voyager | Lucid | UltrachromeHR | Acuity |





# Acquisition & Tracking

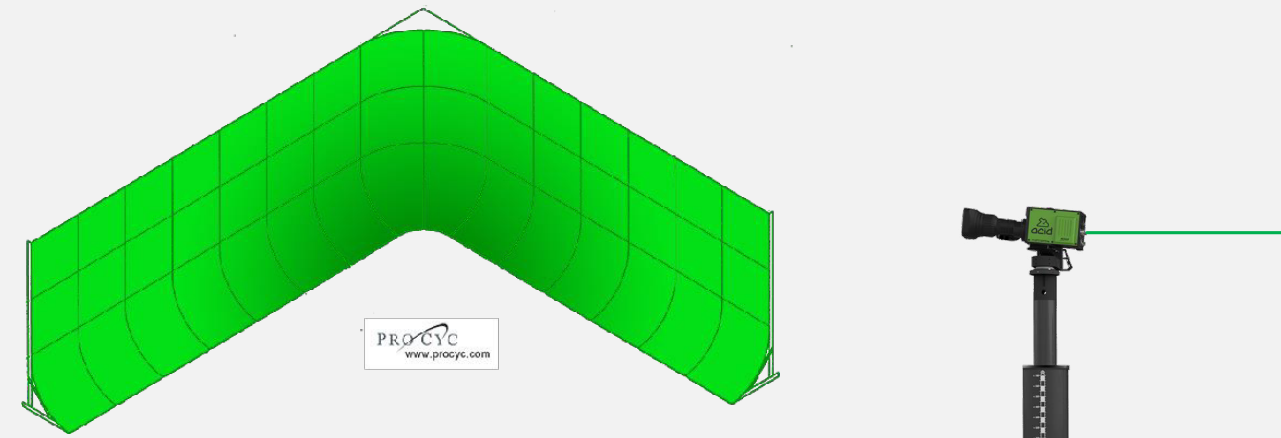

**Chroma Wall**

| Ross + ProCyc Partnership |



**Furio Dolly + Lift S3**

| VR100 / VR600 | S3 or S2 Lift |

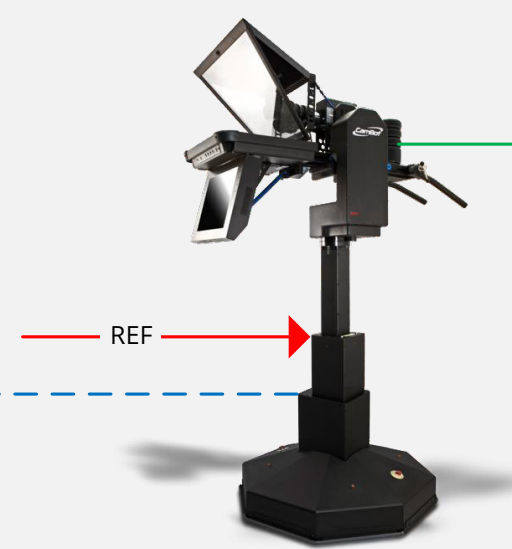

**CamBot 600XY S3**

| 125lb Net Payload |



**Acid AC-H200-UCHR**

| 3- 2/3" UAIT-MOS | 4:4:4 output |

| 1080P | 1080i | 720p |



**Furio Pan / Tilt Head**

| VR100 | VR600 |

| Customer Supplied Tripod |

# Rendering



**Voyager | Unreal Engine**

| Hyper Realistic Rendering |



**Voyager | Unreal Engine**

| Hyper Realistic Rendering |



**Voyager | Unreal Engine**

| Hyper Realistic Rendering |

# Production Operations



**Carbonite MultiViewers**

| Customer Supplied Monitors |



**Rosstalk**

**TouchDrive - TD2S**

| 25 Source buttons | Customer Provided VESA Mount |



**Carbonite Ultra**

| 1, 2 or 3 ME + 4 MiniMEs |

| 24 inputs and 14 Outputs |



**Lucid**

| Virtual Solutions Control |



**NK-3G16**



**Robotic Server**



**SmartShell Control System**

| 3 Axis or 6 Axis |



**Network Switch**

| Customer Supplied |

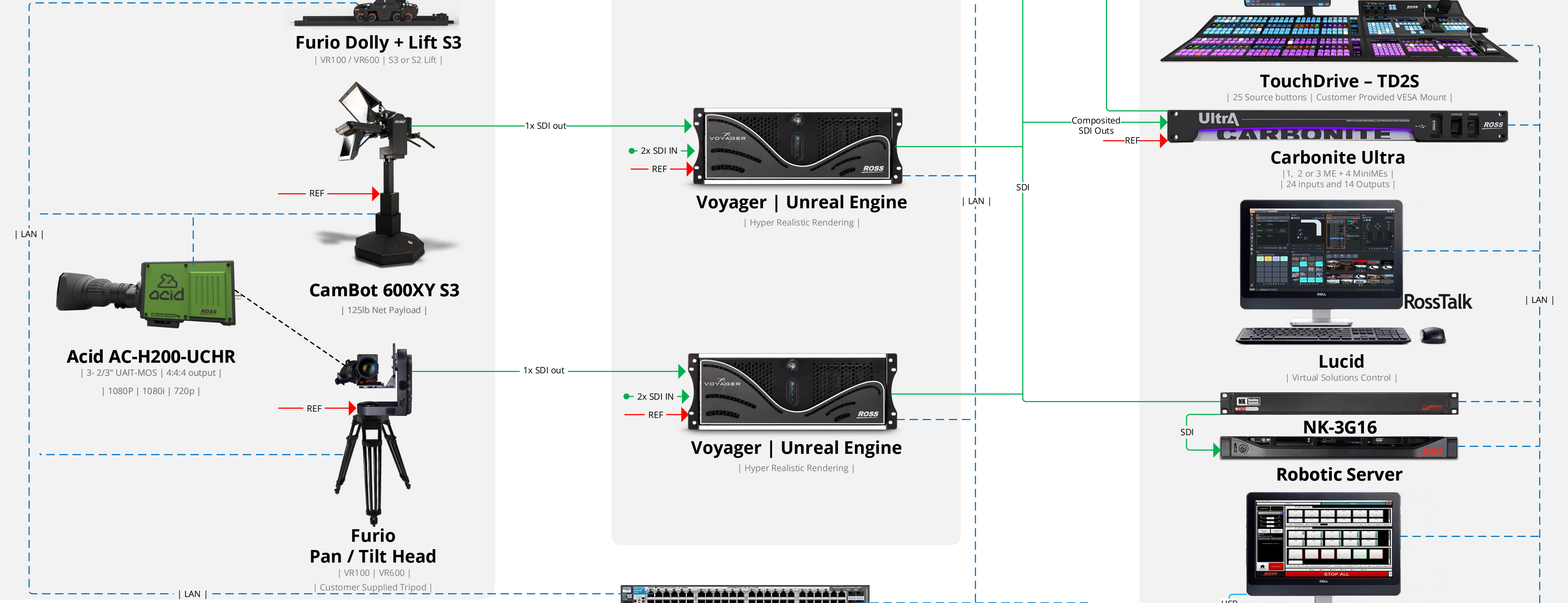

# Ross ARVS Internal Key + Internal Composition

Furio | CamBot | Voyager | Lucid | Carbonite Ultra |

**LEGEND**

- VIDEO
  - SD / HD / 3G SDI
- SYNC
  - VIDEO REF (BB / TRI)
- CONTROL & DATA
  - NETWORK
  - USB



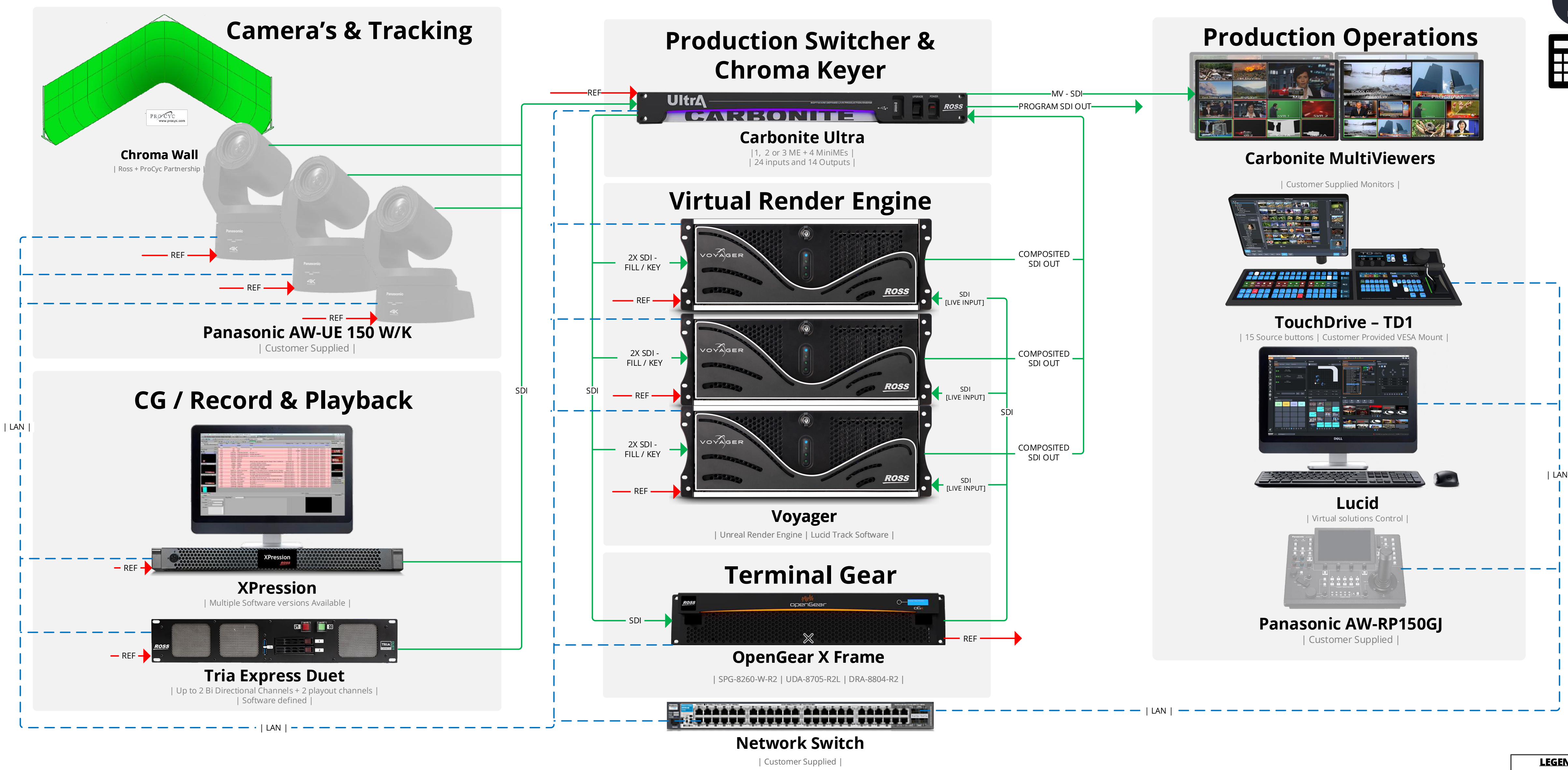

# Ross & Panasonic ARVS Solution

Panasonic AW-UE150 | Voyager | Lucid | openGear | Carbonite Ultra |





### Camera's & Tracking

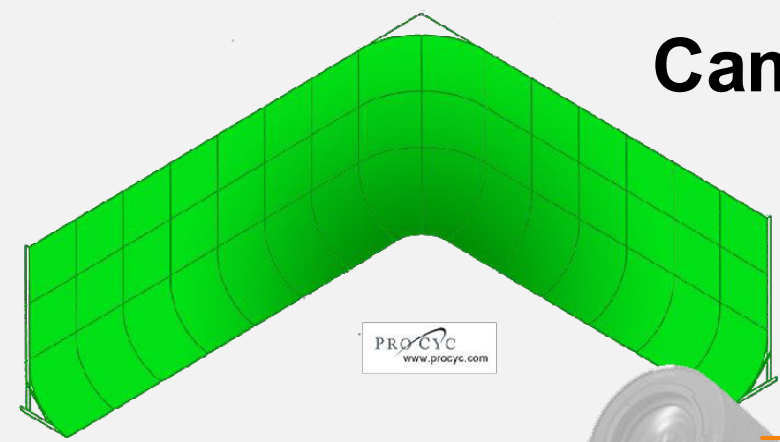

**Chroma Wall**  
| Ross + ProCyc Partnership |

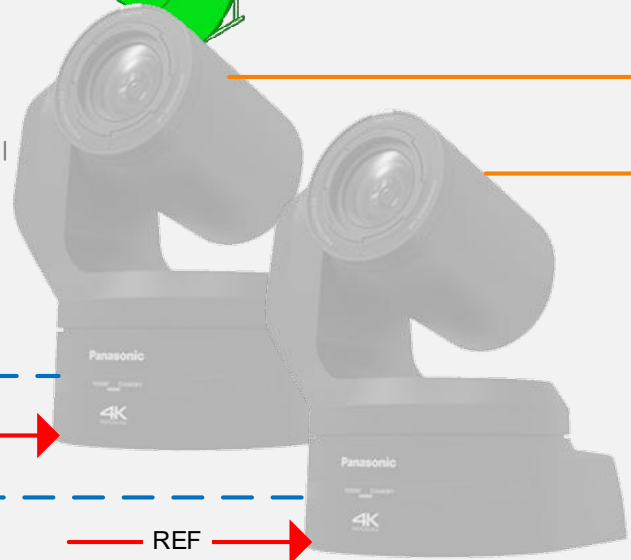

**Panasonic AW-UE 150 W/K**  
| Customer Supplied |

REF

REF

### CG / Record & Playback

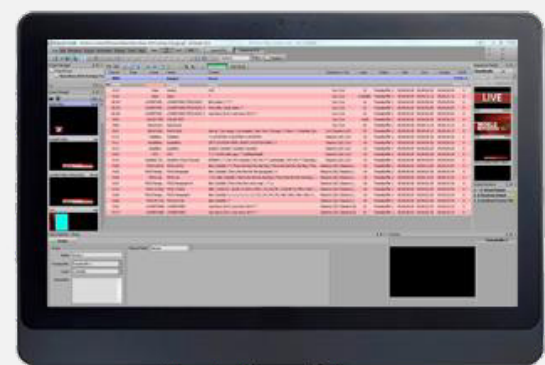

**XPpression UHD**

| XPpression Studio Flex | 1 Channel - 12G |



**Tria+ UHD**

| 2x Bi Directional Channels |  
| XAVC- Intra |

### Chroma Keyer



**Carbonite Ultra**

| 2x UHD Chroma Keyers per frame |

### Virtual Render Engine



**Voyager**

| Unreal Render Engine | UX Track Software |

### Terminal Gear



**OpenGear X Frame**

| SPG-8260-W-R2 | UDA-8705-R2L | DRA-8902-xx |

### Production Operations



**Carbonite MultiViewers**

| Customer Supplied Monitors |



**TouchDrive - TD1**

| 15 Source buttons | Customer Provided VESA Mount |



**Carbonite Ultra - UHD**

| 1 or 2 or ME + 2 MiniMEs |  
| 18 inputs and 10 Outputs | up to 2 MV's |



**Lucid**

| Virtual solutions Control |



**Panasonic AW-RP150GJ**

| Customer Supplied |



**Network Switch**

| Customer Supplied |

#### LEGEND

- VIDEO
- SYNC
- VIDEO REF (BB / TRI)
- CONTROL & DATA
- NETWORK

# Ross & Panasonic AW-UE 150 UHD Solution

Voyager | Lucid | Carbonite Ultra | XPpression | Tria+ UHD



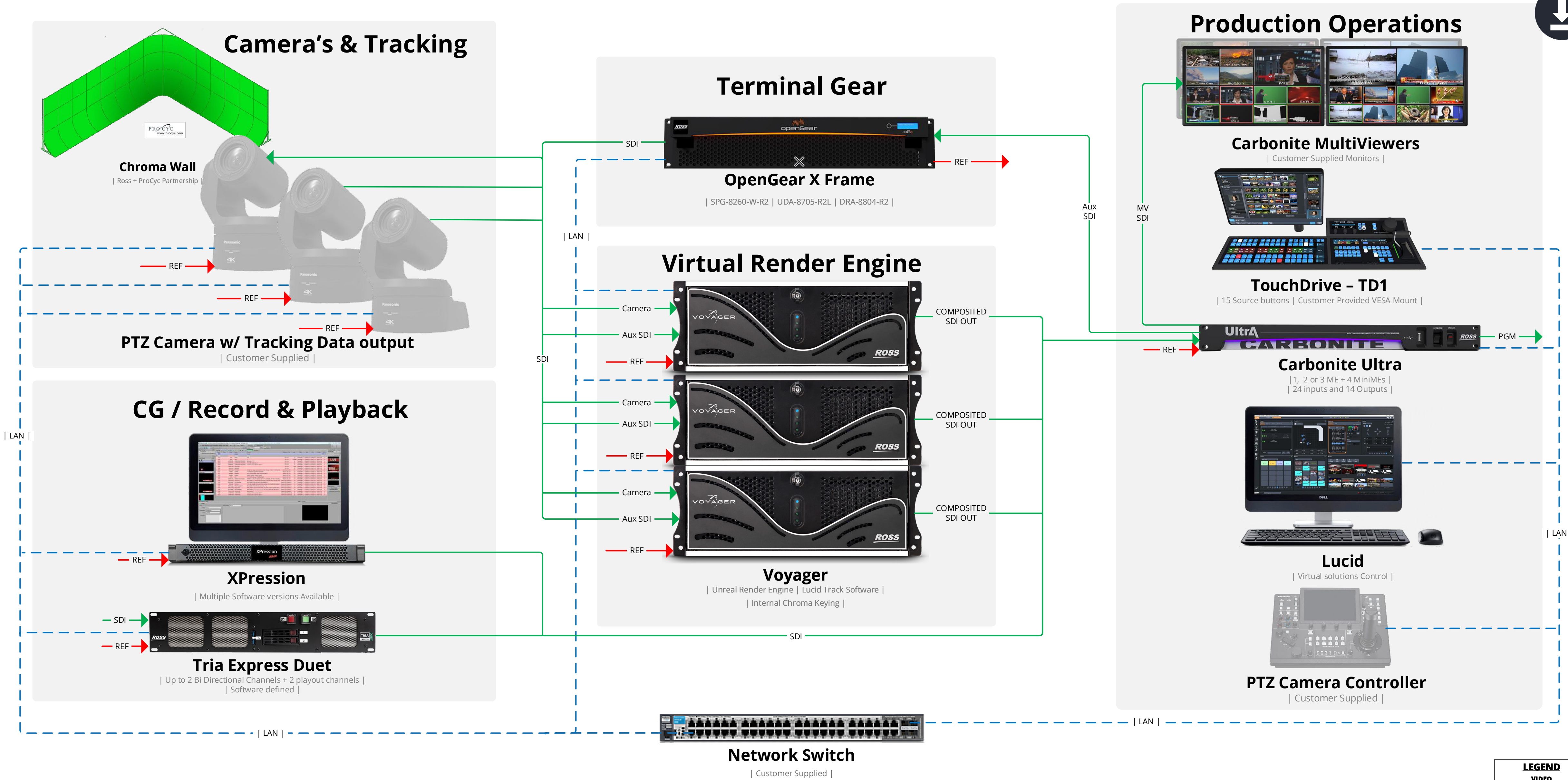

# Ross - PTZ Internal Chroma Keying & Internal Composition

Voyager | Lucid | openGear | Carbonite Ultra |



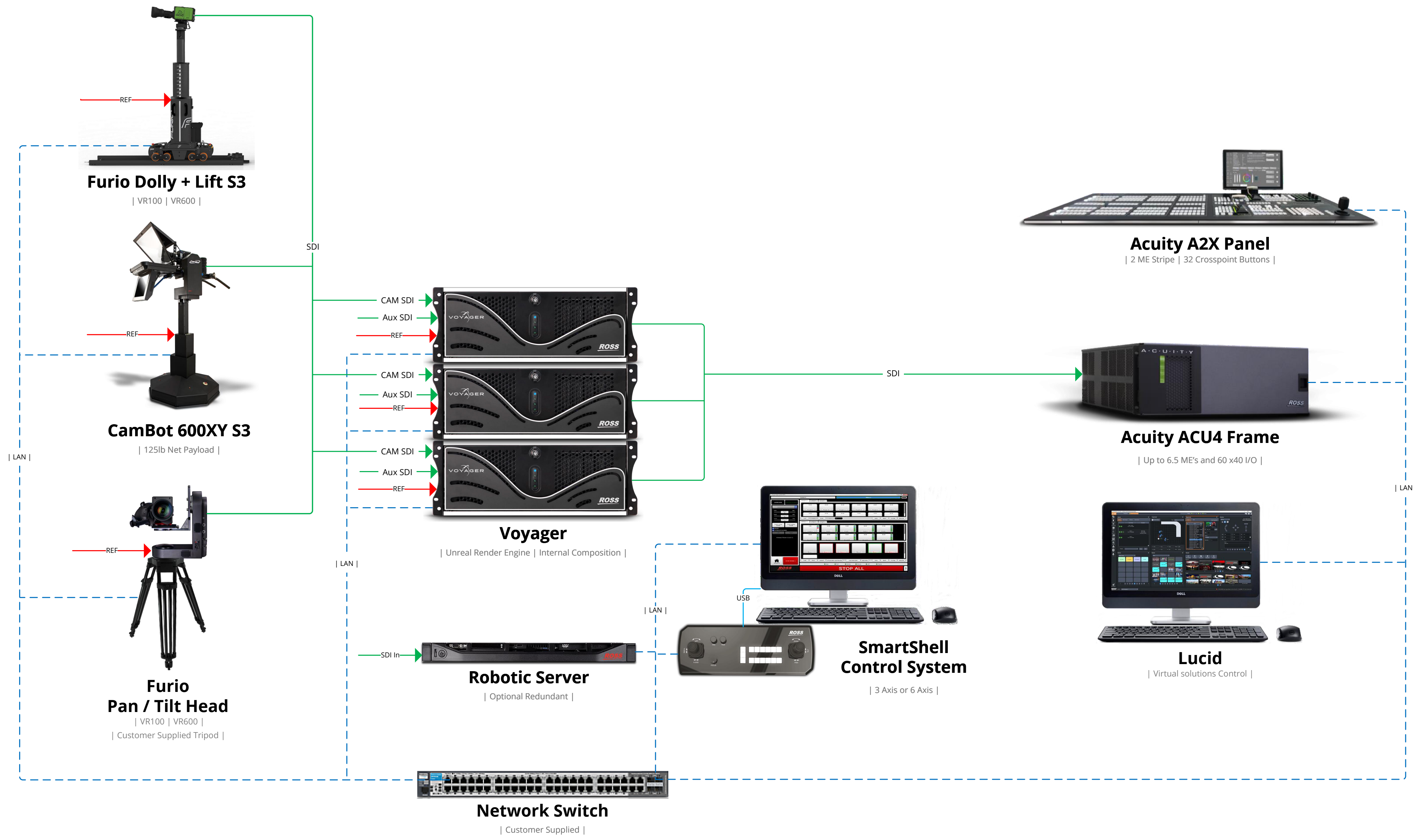

# Ross Voyager Augmented Reality Solution

Furio | Voyager | Lucid | openGear | Acuity |

# ARVS: Augmented Reality Solution





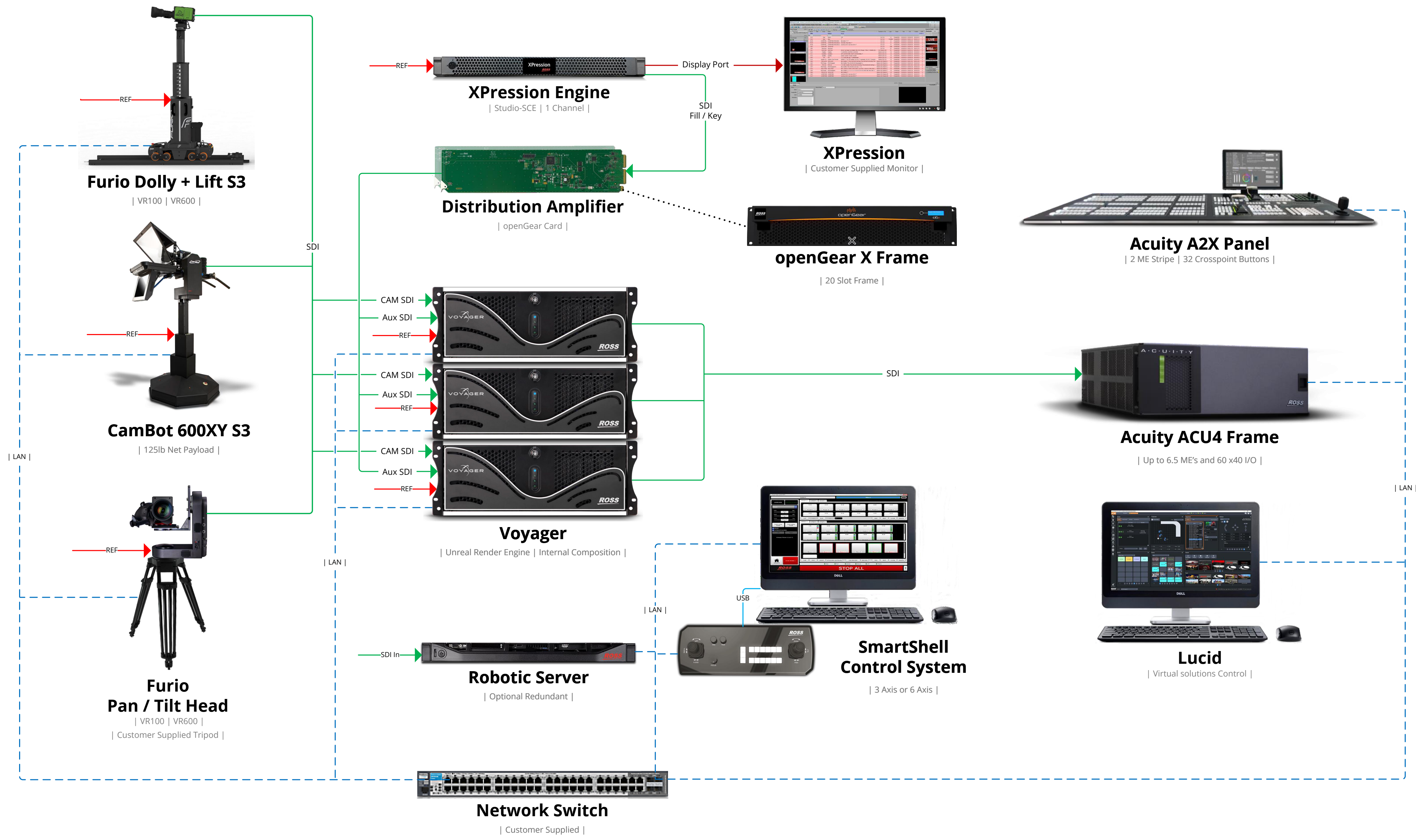
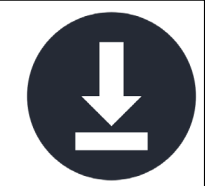

LEGEND	
VIDEO	
SD / HD / 3G SDI	Green line
DISPLAY PORT	Red line
SYNC	Red line with square
VIDEO REF (BB / TRI)	Red line with square
CONTROL & DATA	
NETWORK	Blue dashed line
USB	Blue solid line

# Ross Voyager + XPression Augmented Reality Solution

## ARVS: AR Voyager + XPression Solution

Furio | Voyager | XPression | Lucid | openGear | Acuity |



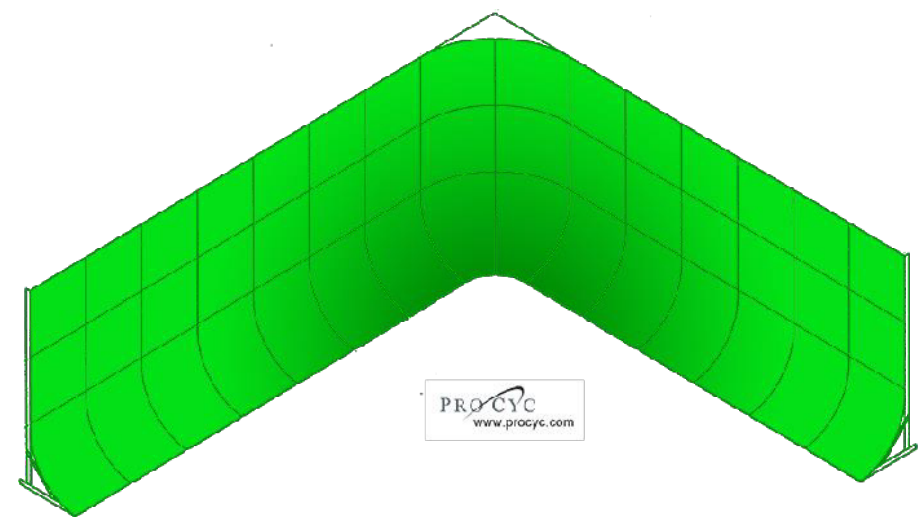

**Chroma Wall**  
| Ross + ProCyc Partnership |

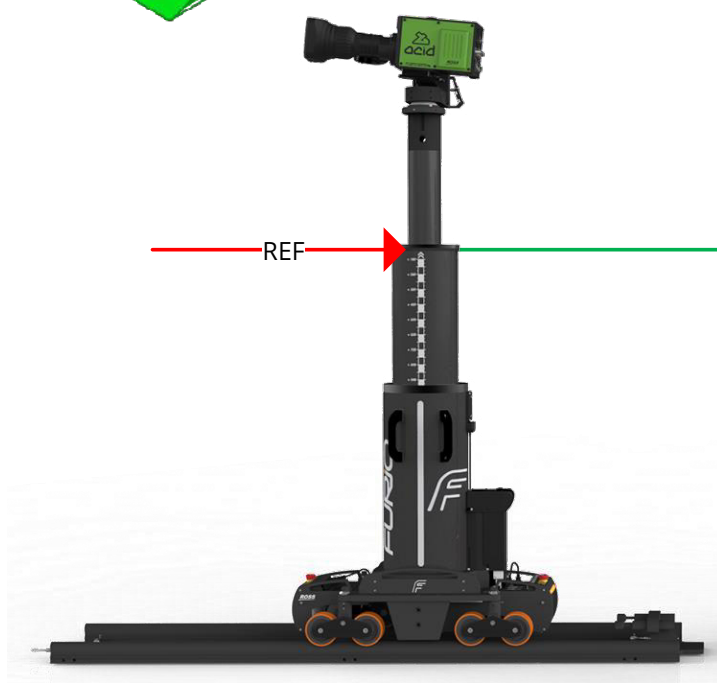

**Furio Dolly + Lift S3**  
| Live | VR100 | VR600 |



**Lucid Studio**  
| Virtual solutions Control |



**PIERO User Interface**  
| Customer Supplied Monitor |



**Voyager**  
| Unreal Render Engine | Virtual Set / Augmented Reality |



**Network Switch**  
| Customer Supplied |



**PIERO Remote 2**  
| Customer Supplied iPad |  
| Requires additional License |



**PIERO Remote Touch**  
| Customer Supplied Hardware |  
| Requires additional License |



**PIERO Network**  
| Customer Supplied |



**Production Switcher**  
| Carbonite Ultra Shown |

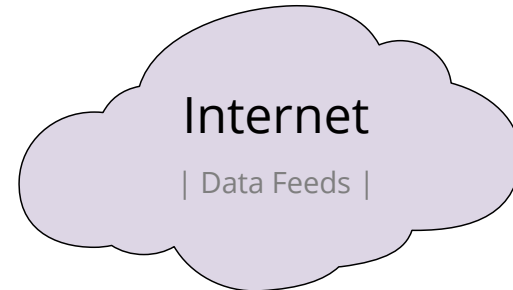

**Internet**  
| Data Feeds |

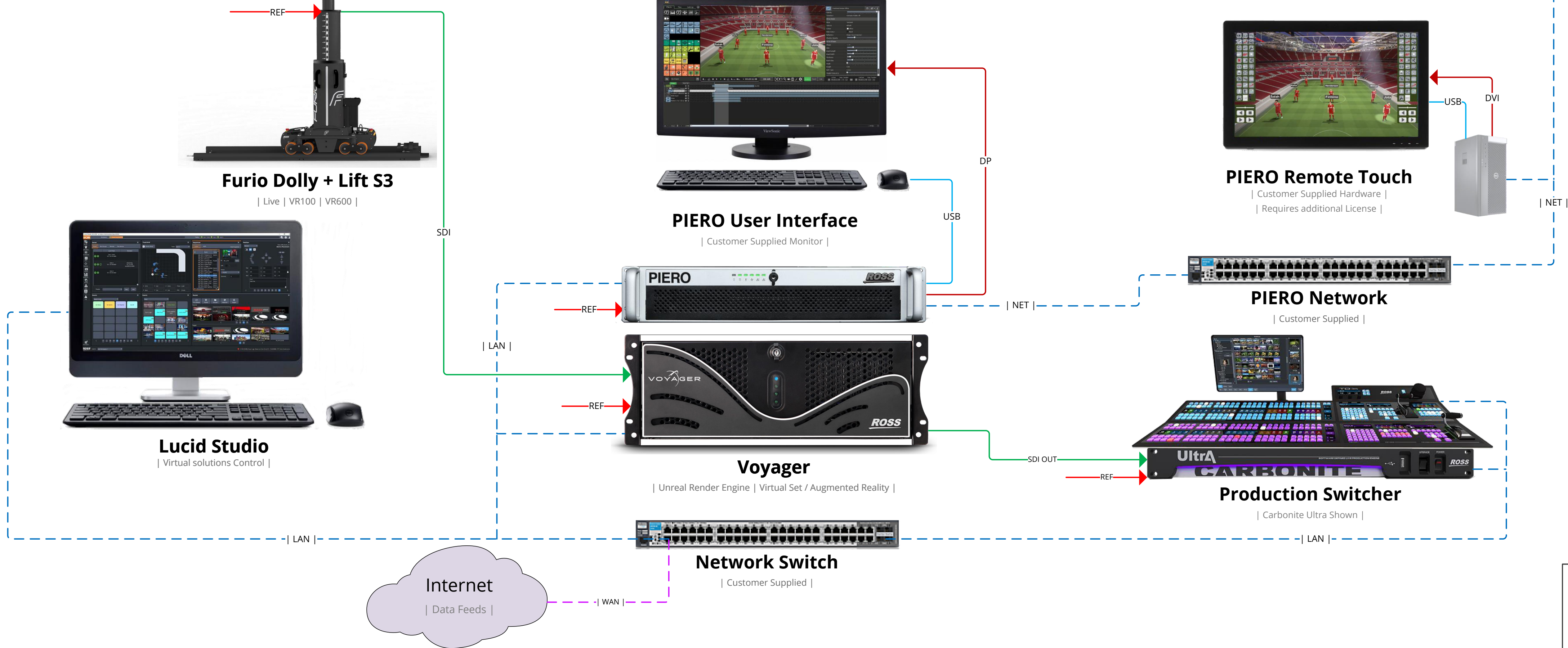

LEGEND	
<b>VIDEO</b>	
<span style="color: green;">■</span>	SD / HD / 3G SDI
<span style="color: red;">■</span>	HDMI / DVI / DP
<b>SYNC</b>	
<span style="color: red;">■</span>	VIDEO REF (BB / TRI)
<b>CONTROL &amp; DATA</b>	
<span style="color: blue;">■</span>	NETWORK
<span style="color: magenta;">■</span>	NETWORK- SECONDARY
<span style="color: cyan;">■</span>	USB

# Ross Voyager & PIERO Solution

Voyager | PIERO | Lucid | Furio | Carbonite Ultra

